

REPLACEMENT FENCE LOCATION

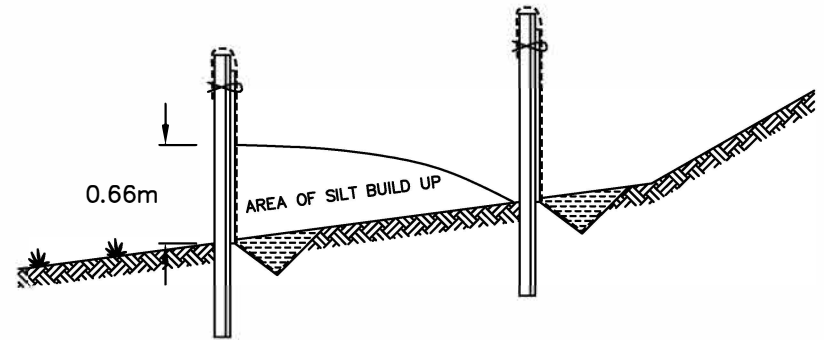

NOTES:

1. SILT CONTROL FENCE SHOULD BE ALIGNED WITH CONTOURS FOR SHEET OVERLAND FLOW.
2. SILT/SEDIMENT CONTROL FENCE IS TO BE LOCATED IN AREAS OF LOW SEDIMENT YIELD ON SLOPES THAT CONFORM TO MTO DRAINAGE MANUAL VOLUME 2 "CHART F4-3C TOPOGRAPHIC FACTOR LS BASED ON SLOPE LENGTH AND GRADIENT."
3. SILT/SEDIMENT CONTROL FENCE SHALL BE INSTALLED WITH FILTER MEDIA FABRIC TOED INTO THE SOIL A MIN. OF 300mm BY EITHER STATIC SLICING OR TRENCH METHODS WITH COMPACTION OF TRENCH MATERIAL MEETING 95% INSITU SOIL STRENGTH.
4. STEEL 'T' BAR POSTS ARE TO BE SPACED MAX. 2500mm ON CENTER.
5. FROZEN GROUND CONDITIONS REQUIRE FILTER FABRIC TO BE BACKFILLED IN TRENCH WITH CLEAR STONE.
6. ALL DIMENSIONS ARE IN MILLIMETRES UNLESS OTHERWISE SHOWN.
7. GEOTEXTILE FABRIC TO BE COMPRISED OF NON-WOVEN U.V. STABILIZED MATERIAL. FABRIC TO BE FOLDED OVER TOP OF FENCE MIN. 300mm AND WIRE FASTENED.

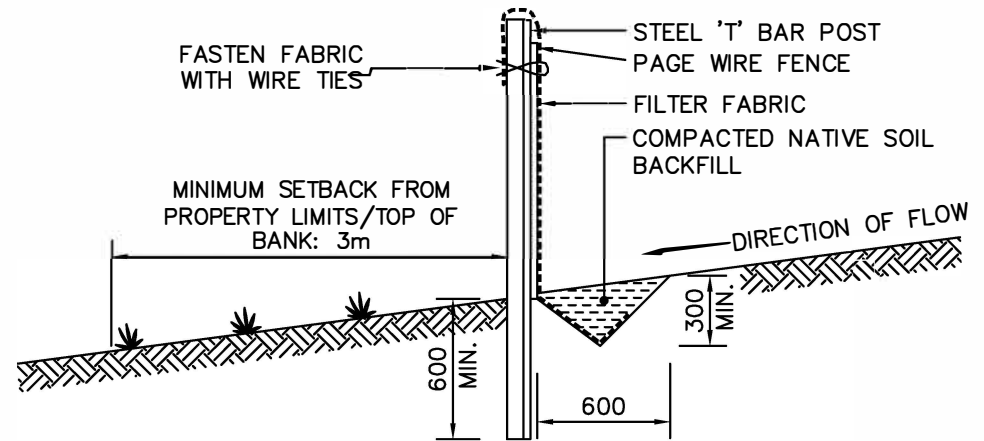

**Nottawasaga Valley
Conservation Authority**

TYPICAL DETAIL OF SILT/SEDIMENT FENCE

NO.	REVISION	APR'D	DATE	

APR'D:	DATE: 03.06.24
DRAWN: A.S.C	SCALE: NTS

BSD-23